

Marine Gear TTMC4A (Mechanical)

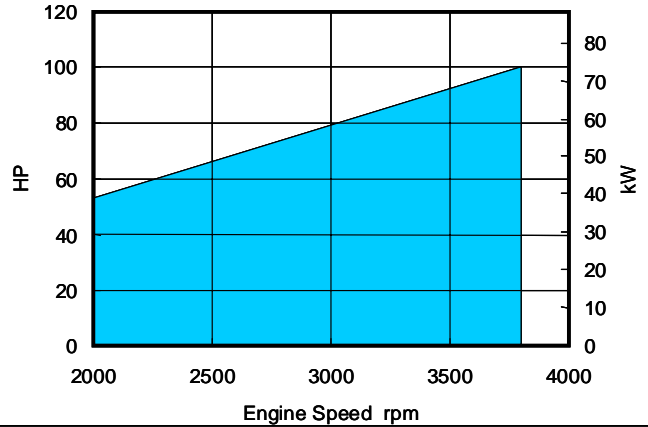

Power Diagram for pleasure use



Specifications

Model		TTMC4A			
Clutch Type		Mechanical angle servo cone			
Input torque capacity (MAX. rpm)		185N.m (3800rpm)			
Reductionratio	Forward	1.47	2.14	2.63	3.30
	Reverse	1.47	2.14	2.63	3.30
Direction of rotation (viewed from stern)	Input shaft	Counter-clockwise			
	Output shaft	Clockwise and Counter-clockwise			
Lubricating oil		SAE#20/#30(without multi-grade oil)			
Lubricating oil capacity		1.3 liter [0.34gal.]			
Dry weight		27.0 kg [59.4 lb]			

"SAE#4 is standard flange". (Option : Other SAE# alternatively Borg Warner size available)

Dimensional Data mm(inch)

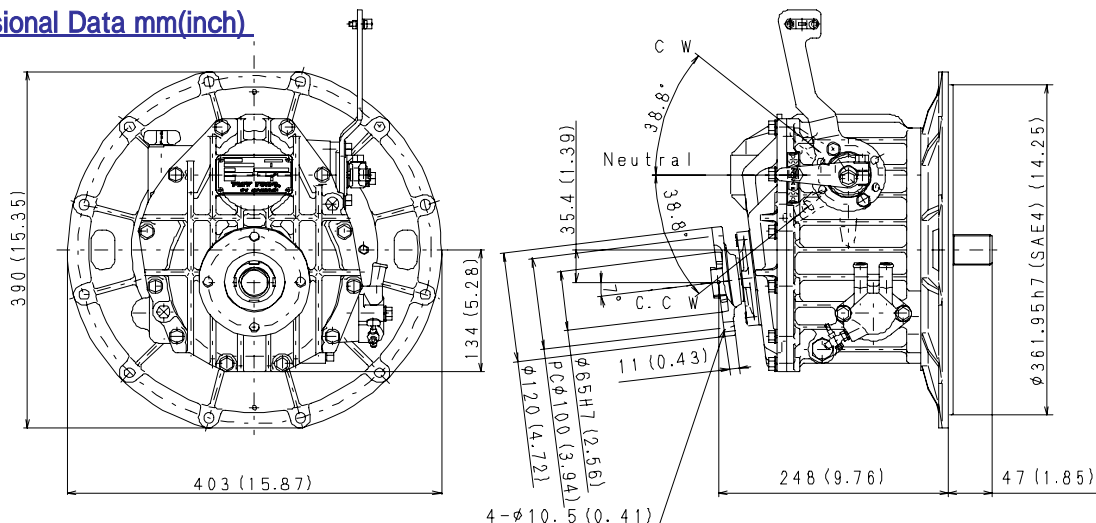

Specifications and design are subject to change without notice.

KANZAKI KOKYUKOKI MFG. CO., LTD.

Address: 2-18-1 INADERA, AMAGASAKI, HYOGO, 661-0981 JAPAN
 Tel : 81-6- 6494-6737 Fax: 81-6- 6494-6829
 Homepage : <http://www.kanzaki.co.jp>

TUFF TORQ CORP.

Address: 5943 Commerce Blvd. Morristown, Tennessee 37814 USA
 Tel : 1(423) 585-1971 Fax: 1(423) 585-2003