

Marine Gear TTMC2P-1(Mechanical)

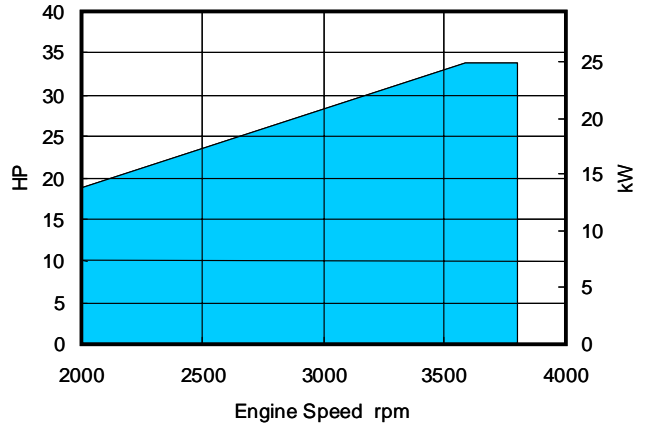

Power Diagram for pleasure use



Specifications

Model		TTMC2P-1		
Clutch Type		Mechanical parallel servo cone		
Input torque capacity (MAX. rpm)		66N.m (3800rpm)		
Reductionratio	Forward	2.21	2.62	3.22
	Reverse	3.06		
Direction of rotation (viewed from stern)	Input shaft	Counter-clockwise		
	Output shaft	Clockwise		
Lubricating oil		SAE#20/#30(without multi-grade oil)		
Lubricating oil capacity		0.3 liter [0.08gal.]		
Dry weight		9.8 kg [21.6 lb]		

"SAE#6 is standard flange". (Option : Other SAE# alternatively Borg Warner size available)

Dimensional Data mm(inch)

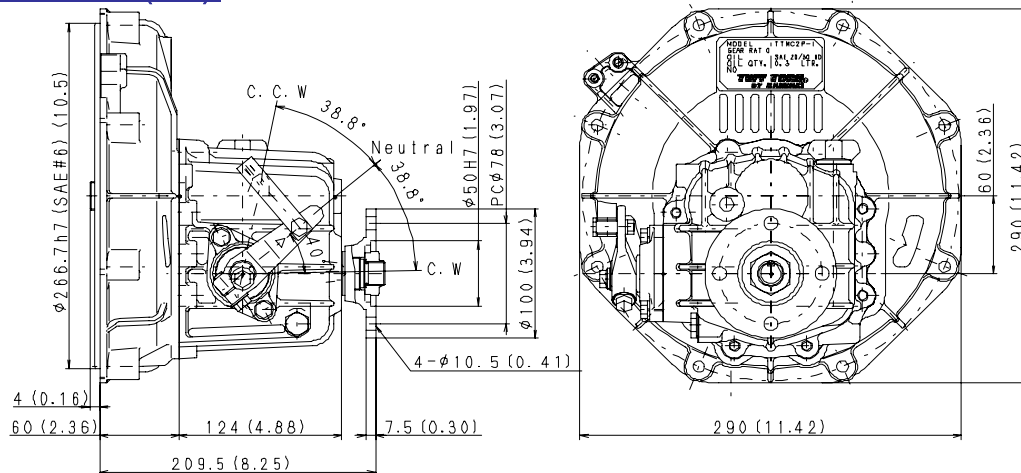

Specifications and design are subject to change without notice.

KANZAKI KOKYUKOKI MFG. CO., LTD.

Address: 2-18-1 INADERA, AMAGASAKI, HYOGO, 661-0981 JAPAN
 Tel : 81-6- 6494-6737 Fax: 81-6- 6494-6829
 Homepage: <http://www.kanzaki.co.jp>

TUFF TORQ CORP.

Address: 5943 Commerce Blvd. Morristown, Tennessee 37814 USA
 Tel : 1(423) 585-1971 Fax: 1(423) 585-2003