

Marine Gear TTM60A (Hydraulic)

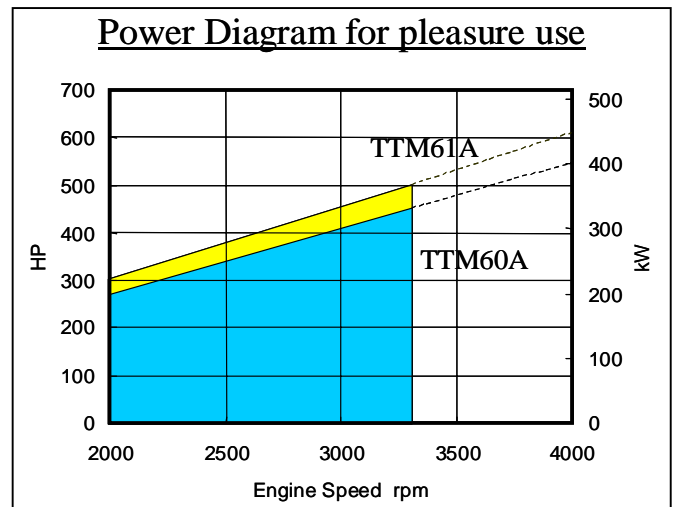

Specifications

Model		TTM60A		
Clutch Type		Hydraulically actuated multi-disc clutch		
Input torque capacity (MAX. rpm)		960N.m (3300rpm)		
Reductionratio	Forward	1.55	2.04	2.43
	Reverse	1.55	2.04	2.43
Direction of rotation (viewed from stern)	Input shaft	Counter-clockwise		
	Output shaft	Clockwise and counter-clockwise		
Lubricating oil		SAE#30(without multi-grade oil)		
Lubricating oil capacity		2.8 liter [0.74gal.]		
Dry weight		58.0kg [127.6 lb](with flange SAE#3, without foot)		

"SAE#3 is standard flange". (Option : Other SAE# alternatively Borg Warner size available)

Trolling Valve and/or PTO available as option .

Dimensional Data mm(inch)

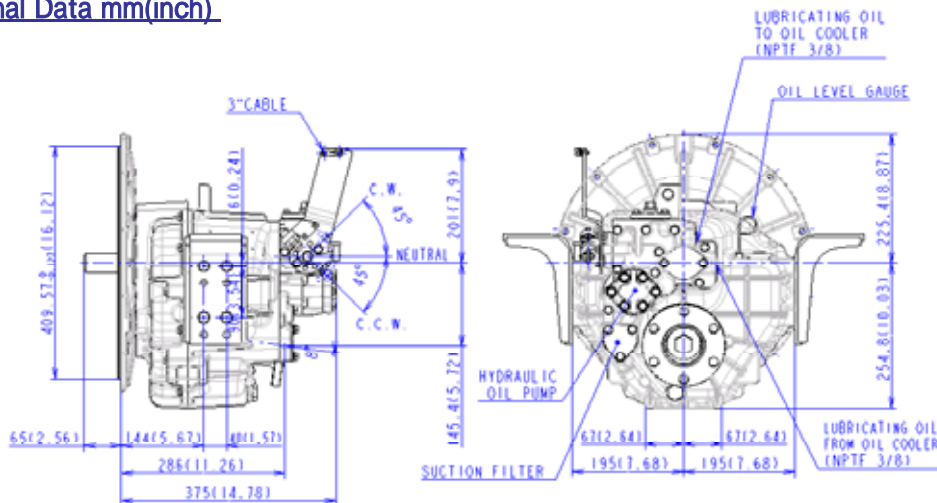

Specifications and design are subject to change without notice.



KANZAKI KOKYUKOKI MFG. CO., LTD.

Address: 2-18-1 INADERA, AMAGASAKI, HYOGO, 661-0981 JAPAN
 Tel : 81-6- 6494-6737 Fax: 81-6- 6494-6829
 Homepage : <http://www.kanzaki.co.jp>



Address: 5943 Commerce Blvd. Morristown, Tennessee 37814 USA
 Tel : 1(423) 585-1971 Fax: 1(423) 585-2003