

# TUFF TORQ

BY KANZAKI

## Marine Gear TTM50V (Hydraulic)



**Power Diagram for pleasure use**

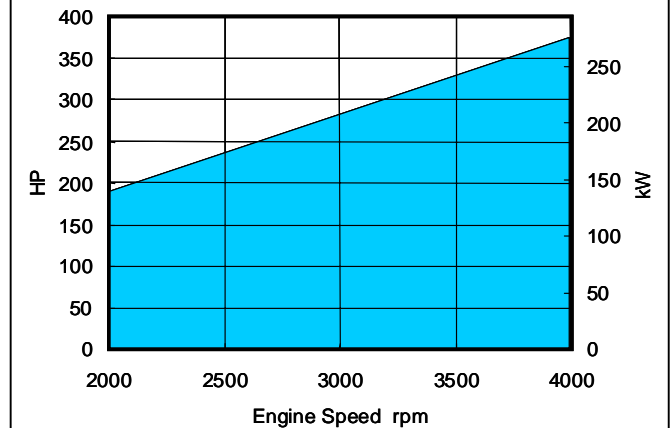

### Specifications

Model		TTM50V			
Clutch Type		Hydraulically actuated multi-disc clutch			
Input torque capacity (MAX. rpm)		660N.m (5500rpm)			
Reductionratio	Forward	1.21	1.57	2.05	2.49
	Reverse	1.21	1.57	2.05	2.49
Direction of rotation (viewed from stern)	Input shaft	Counter-clockwise			
	Output shaft	Clockwise and counter-clockwise			
Lubricating oil		SAE#30(without multi-grade oil)			
Lubricating oil capacity		5.4 liter [1.4gal.]			
Dry weight		58.0kg [127.6 lb](with Borg Warner flange, without foot)			

"Borg Warner is standard flange". (Option : SAE# size available)

Mechanical or Electronic Trolling Valve, Electric Shift and/or PTO available as option.

### Dimensional Data mm(inch)

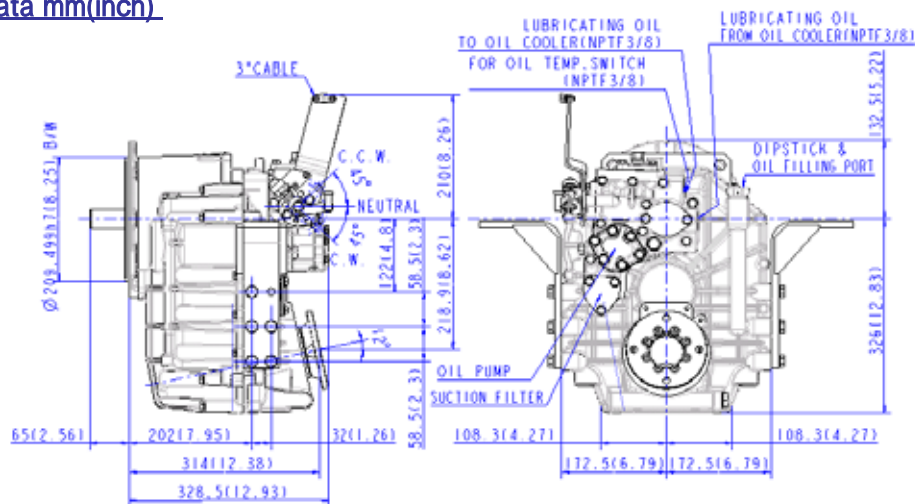

Specifications and design are subject to change without notice.



**KANZAKI KOKYUKOKI MFG. CO., LTD.**

Address: 2-18-1 INADERA, AMAGASAKI, HYOGO, 661-0981 JAPAN  
 Tel : 81-6- 6494-6737 Fax: 81-6- 6494-6829  
 Homepage : <http://www.kanzaki.co.jp>



**TUFF TORQ CORP.**

Address: 5943 Commerce Blvd. Morristown, Tennessee 37814 USA  
 Tel : 1(423) 585-1971 Fax: 1(423) 585-2003