

Marine Gear TTM40A (Hydraulic)

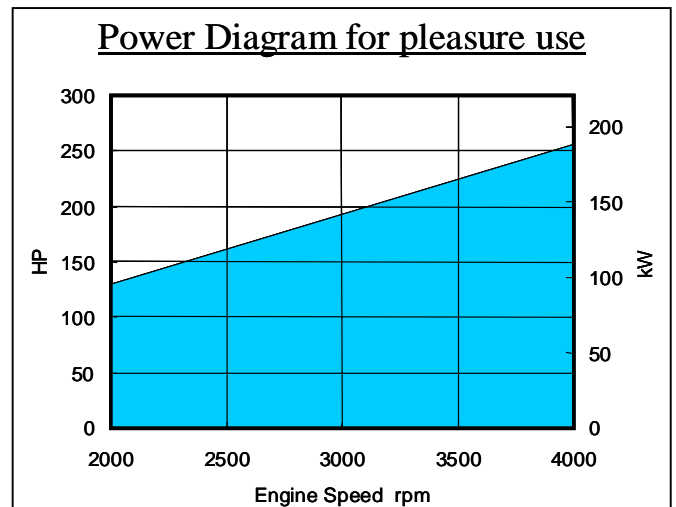

Specifications

Model		TTM40A			
Clutch Type		Hydraulically actuated multi-disc clutch			
Input torque capacity (MAX. rpm)		450N.m (5500rpm)			
Reductionratio	Forward	1.24	1.54	2.04	2.45
	Reverse	1.24	1.54	2.04	2.45
Direction of rotation (viewed from stern)	Input shaft	Counter-clockwise			
	Output shaft	Clockwise and counter-clockwise			
Lubricating oil		SAE#30(without multi-grade oil)			
Lubricating oil capacity		2.0 liter [0.53gal.]			
Dry weight		29.5kg [64.9 lb](with Borg Warner flange, without foot)			

"Borg Warner is standard flange". (Option : SAE# size available)

Trolling Valve and/or PTO available as option.

Dimensional Data mm(inch)

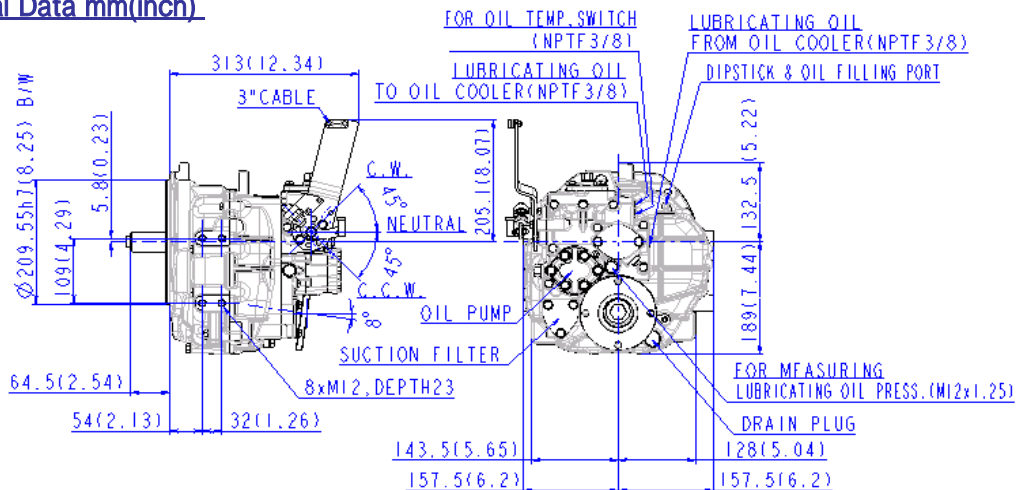

Specifications and design are subject to change without notice.



KANZAKI KOKYUKOKI MFG. CO., LTD.

Address: 2-18-1 INADERA, AMAGASAKI, HYOGO, 661-0981 JAPAN
 Tel : 81-6- 6494-6737 Fax: 81-6- 6494-6829
 Homepage : <http://www.kanzaki.co.jp>



Address: 5943 Commerce Blvd. Morristown, Tennessee 37814 USA
 Tel : 1(423) 585-1971 Fax: 1(423) 585-2003